

## TXMC889 Four Channel SFP Gigabit Ethernet

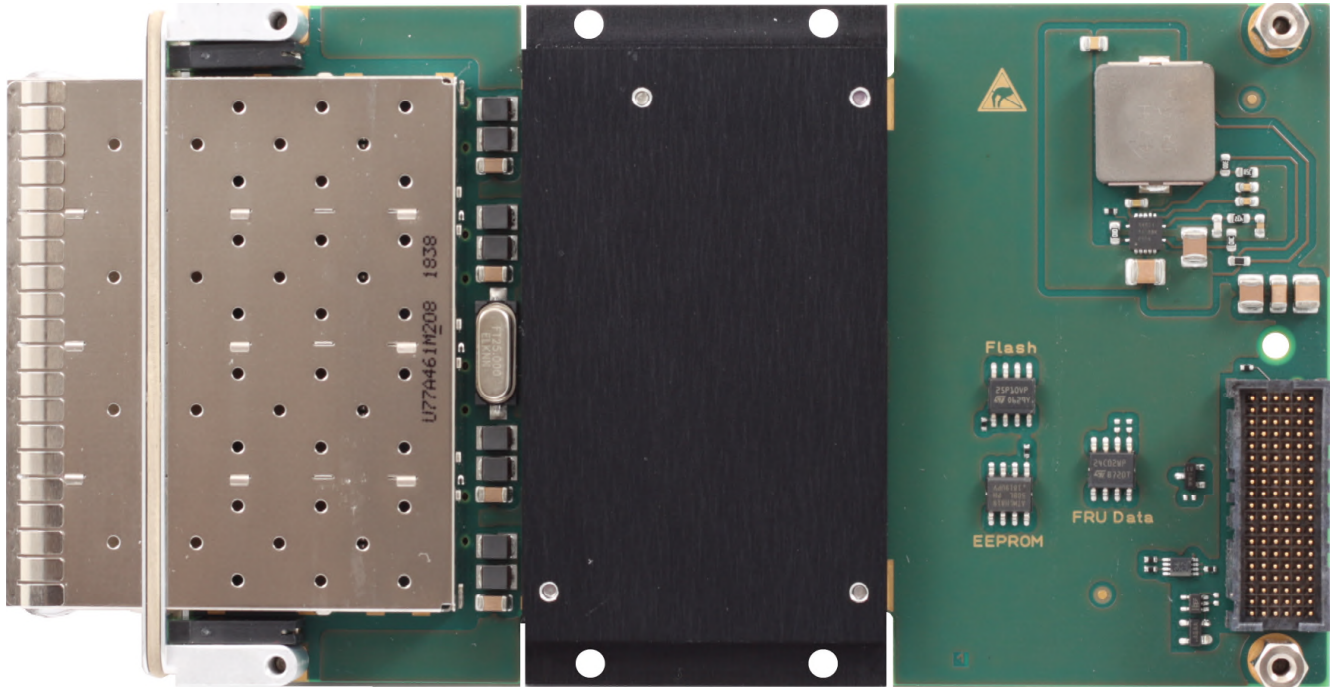

### Application Information

The TXMC889 is a Switched Mezzanine Card (XMC) compatible module providing a four channel Gigabit Ethernet Small Form Factor Pluggable (SFP) interface.

The XMC-Connector P15 provides access to the Intel™ I350-AM4 quad port Gigabit Ethernet controller via an x4 PCIe link.

The TXMC889's SFP Cages accept various SFP transceiver modules. These four SFP hosts are connected to the Ethernet Controller's SerDes Interfaces.

The following transceiver modules have been successfully tested with the TXMC889:

- Intel XDACBL1M (SFP+ Direct Attach Twinaxial Cable)
- Finisar FCBG110SD1C01 (SFP+ SFPwire Active Optical Cable)
- Intel E10GSFPSR (SFP+ 1000BASE-SX)
- Finisar FTLX8574D3BCV (SFP+ 1000BASE-SX)
- Intel E10GSFPLR (SFP+ 1000BASE-LX)
- Finisar FTLX1475D3BCV (SFP+ 1000BASE-LX)

- Finisar FTLF8519P3BTL (SFP 1000BASE-SX)
- Finisar FTLF1318P3BTL (SFP 1000BASE-LX)
- Finisar FCLF8522P2BTL (SFP 1000BASE-T)

All compatible transceivers modules and replacements of the tested modules will also work properly with the TXMC889.

The controller is equipped with a 32 Mbit serial flash memory for Boot ROM and a 128 Kbit EEPROM storing configuration data. LEDs in the front panel indicate the different network activities.

For preconfigured variants of the hardware module containing transceiver modules, please contact TEWS.

The TXMC889-10R provides four Gigabit Ethernet Interfaces via front panel SFP connectors.

#### Software support:

- Software support for Intel™ I350 at [www.intel.com](http://www.intel.com)
- For operating systems not supported by Intel™, please contact TEWS.

### Technical Information

- Form Factor: Short single-width XMC module conforming to ANSI/VITA 42.0
  - Board size: 124 mm x 74 mm
- x4 PCI Express (Base Specification 2.1) compliant interface conforming to ANSI/VITA 42.3
- IPMI resource: FRU hardware definition information stored in on-board EEPROM
- Quad Port Intel™ I350-AM4 Gigabit Ethernet controller providing SerDes Interfaces
- Four SFP Cages
- Direct Attach Twinaxial Cable
- SFPwire Active Optical Cable
- 1000Base-SX
- 1000Base-LX
- 1000Base-T
- 32 Mbit serial flash memory for Boot ROM
- 128 Kbit EEPROM storing configuration data
- Operating temperature -40°C to +85°C
- MTBF (MIL-HDBK217F/FN2 G<sub>B</sub> 20°C) 431000 h

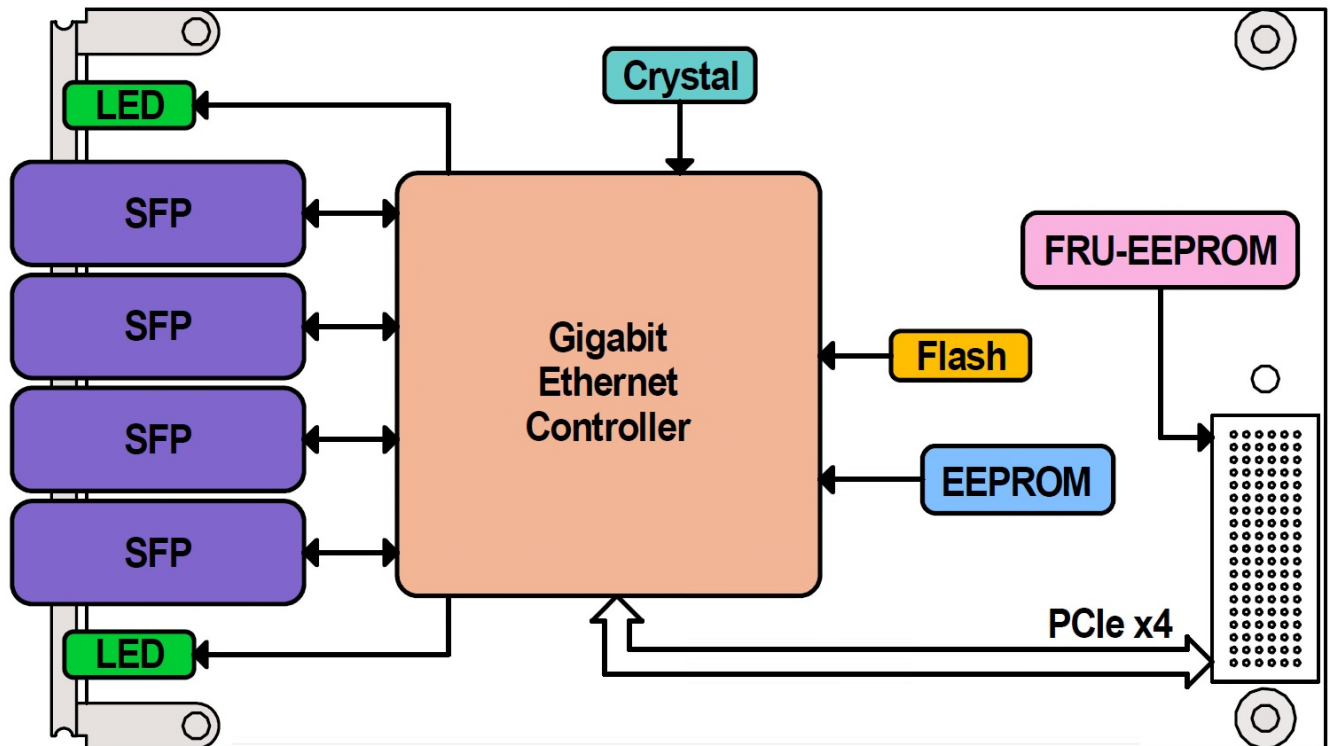

### Order Information

#### RoHS Compliant

**TXMC889-10R** Four channel Gigabit Ethernet interface SFP front panel I/O

For the availability of non-RoHS compliant (lead solder) products please contact TEWS.

#### Documentation

**TXMC889-DOC** User Manual