

## TPMC851 Multifunction I/O (16 bit AD, 16 bit DA, TTL I/O, Counter)

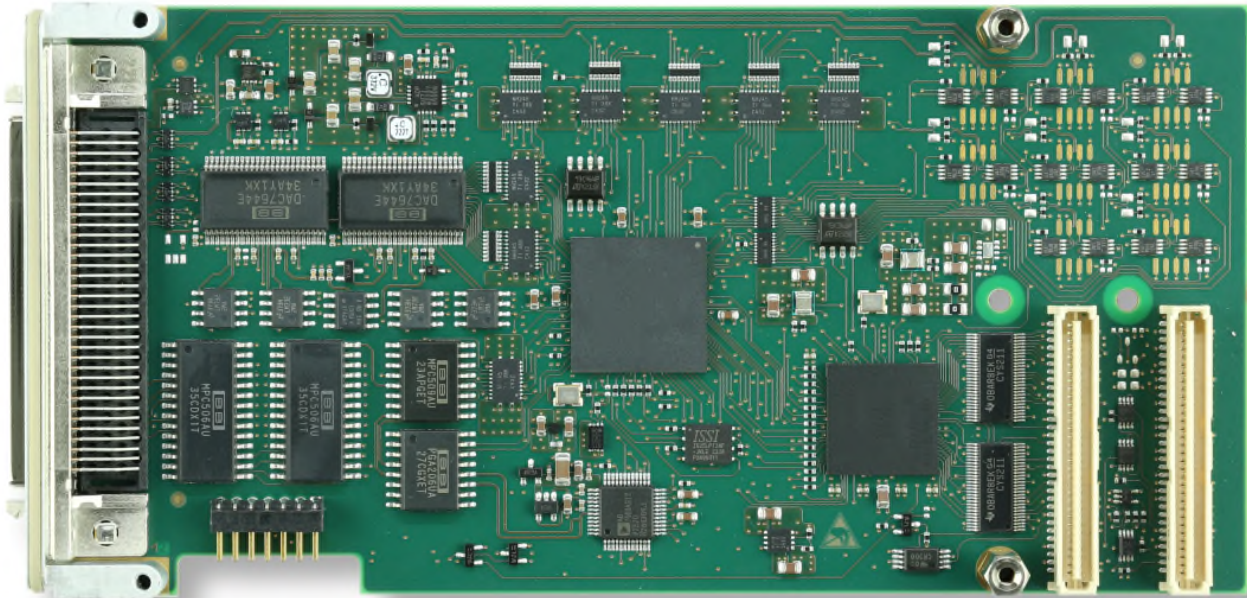

### Application Information

The TPMC851 combines 32 single ended / 16 differential channels of 16 bit multiplexed analog input, 8 channels of 16 bit analog output, 16 digital I/O lines and two 32 bit multi-purpose counters on a standard single-width PMC module.

A 16 bit ADC converts 32 single-ended or 16 differential multiplexed ADC input channels. The conversion time is up to 1.25 $\mu$ s without channel/gain change and up to 17.25  $\mu$ s with channel/gain change (ADC throughput rate up to 250ksp/s). The input multiplexer of the A/D circuit offers analog overvoltage protection of up to 70Vpp. A programmable gain amplifier allows gains of 1, 2, 4 or 8 resulting in input voltage ranges of  $\pm 10$ V,  $\pm 5$ V,  $\pm 2.5$ V or  $\pm 1.25$ V.

The ADC part of the TPMC851 can operate in Manual Mode or Sequencer Mode:

- Manual Mode  
In Manual Mode the multiplexer, programmable gain amplifier and the converter are fully controlled by the user. A conversion for a selected channel / gain can be started automatically after the settling time has elapsed, or manually by the user.
- Sequencer Mode  
In Sequencer Mode each of the A/D channels can be independently enabled and configured for the

sequencer. The sequencer can run continuously, at specific time intervals, or it may be triggered by an external event. Conversion data is buffered in a data RAM.

The 8 analog output channels are provided by eight 16 bit digital to analog converters (DACs). The conversion time is 10  $\mu$ s. An operational amplifier drives the full-scale range of  $\pm 10$ V and is capable to drive high capacitive loads. Similar to the analog inputs a sequencer can control the analog outputs.

Following operation modes are available:

- Immediate Update: Updates the DAC output immediately when new data is written to the DAC channel.
- Simultaneous Update: DAC data is buffered and all DAC outputs are updated simultaneously on a trigger event:
  - Manual Update: Updates all DAC outputs on a manual event (register write)
  - Trigger Update: Updates all DAC outputs on an external event
  - Sequencer Update: Updates all DAC outputs after the sequencer timer has elapsed

## The Embedded I/O Company

Factory determined A/D and D/A correction data is stored in an EEPROM unique to each individual TPMC851 card.

The 16 digital TTL tri-state I/O lines with 4.7kΩ pull up resistors are ESD protected. All 16 lines can be individually programmed as input or output, and can generate an interrupt on negative and positive transitions. Each input has an electronic debounce circuit to prevent short spikes on the input lines to cause an interrupt. The digital inputs can supply the external signals for the ADC and DAC sequencer and the 32 bit counters.

Additionally the TPMC851 offers two 32 bit multi-purpose counters. The counters include 32 bit preload registers and 32 bit compare registers. The 32 bit counters can be fed with an internal clock or with an external signal supplied by the digital inputs. The 4 input modes of the counters determine the interpretation of the input signals. Additionally 3 count modes, which describe the behavior of the counters, and 4 control modes are available:

- Counter Input Modes
  - Internal clock with prescaler
  - Up/Down count
  - Direction count
  - Quadrature count with 1x, 2x or 4x resolution multiplier
- Count Modes
  - Cycling Counter
  - Divide-by-N
  - Single Cycle
- Control Modes
  - Load on Control
  - Latch on Control
  - Gate on Control
  - Reset on Control

Software Support (TPMC851-SW-xx) for different operating systems is available.

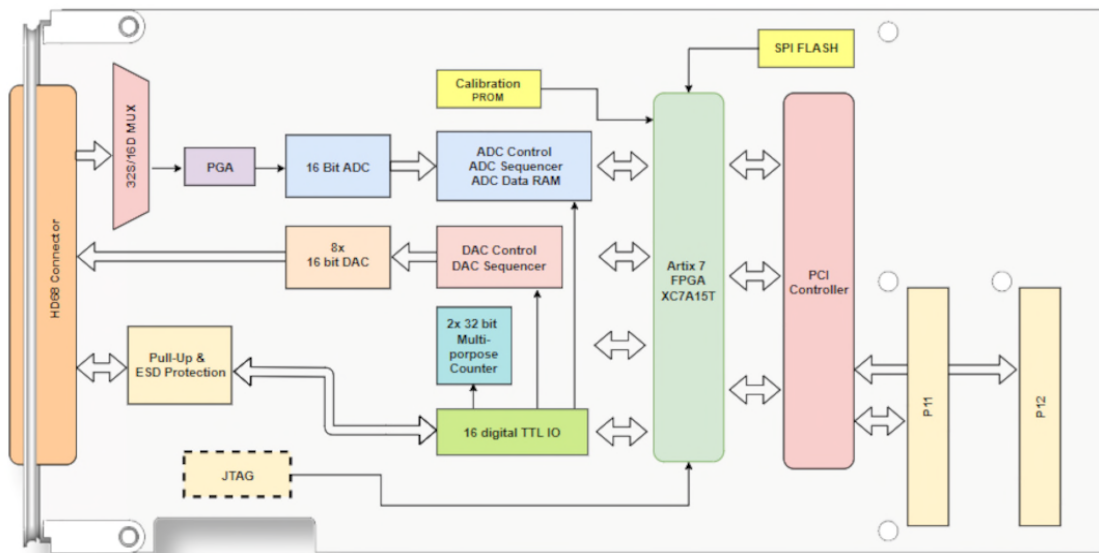

### Technical Information

- Standard single-width 32 bit PMC module conforming to IEEE P1386.1
  - PCI3.0 compatible Interface, 32 bit, 33 MHz
  - PCI I/O signaling voltage 5V and 3.3V
- 32 channels single-ended or 16 channel differential 16 bit multiplexed analog input
  - Programmable gain amplifier (gain 1, 2, 4 or 8)
  - Full-scale input range:  $\pm 10V$  (at gain 1)
  - Conversion time depends on mode: min 1.25  $\mu s$ , max 17.25  $\mu s$
  - 70Vpp overvoltage protection
  - Sequencer
- 8 channels 16 bit analog output
  - Output voltage:  $\pm 10V$
  - Conversion time: 10  $\mu s$
  - Up to 10,000pF capacitive load
  - Sequencer
- 16 digital TTL I/O lines with pull up resistors
  - Individually programmable as input or output
  - Programmable debounce time (100ns – 6.55ms)
  - Interrupt capable
  - 32mA source/sink capable
  - 4.7k $\Omega$  pull-up resistor
  - ESD protected
- 2 multi-purpose counters (32 bit)
  - 32 bit preload registers
  - 32 bit compare registers
  - Various count- and control modes
  - Count frequency: External clock up to 10 MHz; internal clock 5, 10, 20 or 40 MHz
- Factory determined A/D and D/A correction data stored in EEPROM
- Operating temperature -40°C to +85°C
- MTBF (MIL-HDBK217F/FN2 G<sub>B</sub> 20°C)  
TPMC851-10R: 213573 h

### Order Information

#### RoHS Compliant

**TPMC851-10R** Multifunction I/O, 32x 16 bit A/D  $\pm 10V$ , 8x 16 bit D/A  $\pm 10V$ , 16x TTL I/O, 2x 32 bit Counters, HD68

For the availability of non-RoHS compliant (lead solder) products please contact TEWS.

#### Software

**TPMC851-SW-25** Integrity Software Support  
**TPMC851-SW-42** VxWorks Software Support  
**TPMC851-SW-65** Windows Software Support  
**TPMC851-SW-82** Linux Software Support  
**TPMC851-SW-95** QNX Software Support

For other operating systems please contact TEWS.

#### Related Products

**TA304** Cable Kit for Modules with HD68 Connector