

TPMC500 32 Channels of Isolated 12 bit A/D

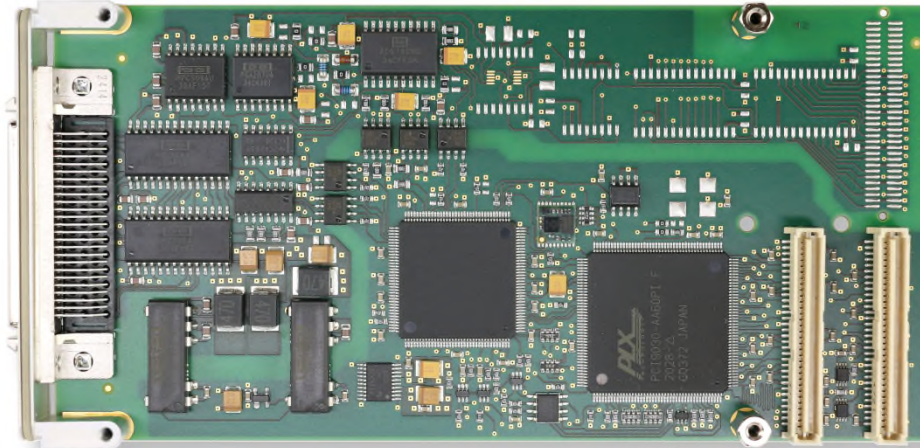

Application Information

The TPMC500 is a PCI Mezzanine Card compatible module providing 32 galvanically isolated multiplexed 12 bit ADC channels. The data acquisition and conversion time is mode-dependent: Maximum 10 μ s without channel / gain change, maximum 12.5 μ s with channel / gain change.

The ADC input channels can be software configured to operate in single-ended mode (up to 32 input channels) or differential mode (up to 16 input channels). Mixed mode operation is also possible.

The ADC multiplexer is overvoltage protected up to 70Vpp. A programmable gain amplifier allows gains of 1, 2, 5, 10 (TPMC500-10R, -12R, -20R and -22R) or 1, 2, 4, 8 (TPMC500-11R, -13R, -21R and -23R). For a gain of 1, the full-scale input voltage range is +/-10V for the TPMC500-10R, -11R, -20R, -21R and 0V to 10V for the TPMC500-12R, -13R, -22R, -23R.

Additionally the TPMC500 provides a sequencer to control the analog inputs without wasting CPU time.

Each channel can be independently enabled and configured by a sequencer instruction RAM. After the last instruction of a programmed sequence has been completed the ADC data of all channels enabled for the sequence are stored in the data RAM.

The repeat frequency of the sequencer can be programmed by using the sequence timer. The sequence timer is programmable from 100 μ s to 6.5535sec in steps of 100 μ s. Whenever the timer reaches the programmed value the sequencer starts a new sequence. A special function is the sequencer continuous mode. It is activated, if the sequence timer register is set to 0. In this mode the sequencer will start again with the first instruction of the sequence as soon as the last instruction of the previous sequence has been completed.

Each TPMC500 is factory calibrated. The calibration data is stored in an EEPROM unique to each TPMC500.

Software support (TPMC500-SW-xx) is available for different operating systems.

Technical Information

- Standard single-width 32 bit PMC module conforming to IEEE P1386.1
- PCI 2.1 compliant interface
- 3.3V and 5V PCI Signaling Voltage
- Board size: 149 mm x 74 mm
- 32 single-ended or 16 differential channels of isolated 12 bit A/D conversion
- Acquisition and conversion time up to 10 μ s without and up to 12.5 μ s with channel / gain change
- ESD protected input multiplexer
- Programmable gain amplifier: gain 1, 2, 5, 10 or 1, 2, 4, 8 (order option)
- 12 bit A/D converter with internal S/H and reference
- Full-scale input range +/-10V or 0-10V (order option)
- Interrupt capability at end-of-conversion
- Factory calibrated, calibration information stored in EEPROM

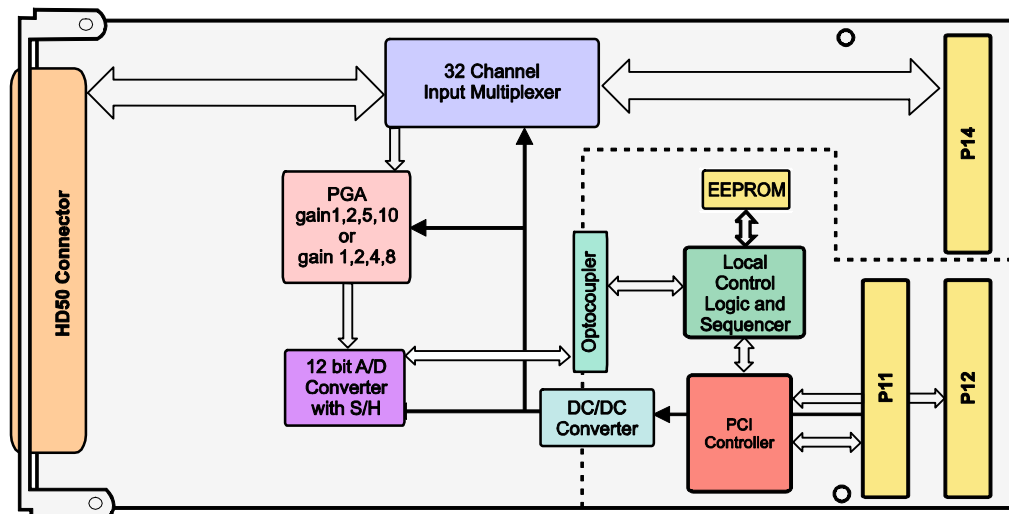

Block Diagram

Order Information

RoHS Compliant

TPMC500-10R	32 Channel Isolated Multiplexed 12 bit A/D, gain 1,2,5,10, +/-10V, HD50
TPMC500-11R	32 Channel Isolated Multiplexed 12 bit A/D, gain 1,2,4,8, +/-10V, HD50
TPMC500-12R	32 Channel Isolated Multiplexed 12 bit A/D, gain 1,2,5,10, 0-10V, HD50
TPMC500-13R	32 Channel Isolated Multiplexed 12 bit A/D, gain 1,2,4,8, 0-10V, HD50
TPMC500-20R	32 Channel Isolated Multiplexed 12 bit A/D, gain 1,2,5,10, +/-10V, P14 I/O
TPMC500-21R	32 Channel Isolated Multiplexed 12 bit A/D, gain 1,2,4,8, +/-10V, P14 I/O
TPMC500-22R	32 Channel Isolated Multiplexed 12 bit A/D, gain 1,2,5,10, 0-10V, P14 I/O
TPMC500-23R	32 Channel Isolated Multiplexed 12 bit A/D, gain 1,2,4,8, 0-10V, P14 I/O

For the availability of non-RoHS compliant (lead solder) products please contact TEWS.

Software

TPMC500-SW-25	Integrity Software Support
TPMC500-SW-42	VxWorks Software Support (Legacy and VxBus-Enabled Software Support)
TPMC500-SW-65	Windows Software Support
TPMC500-SW-82	Linux Software Support
TPMC500-SW-95	QNX Software Support

For other operating systems please contact TEWS.

Related Products

TA301	Cable Kit for modules with HD50 connector
TPIM001	PIM I/O Module, HD50 connector