

TIP102 Motion Controller using Incremental Encoder

Application Information

The TIP102 family consists of IndustryPack® compatible modules with complete one or two axes high precision motion control interfaces, using incremental encoder with RS422 or TTL signal level for position feedback. The transition module TIP102-TM-xx is required for the signal conditioning and optional galvanically isolation of the various input and output signals.

The position feedback is provided by an incremental encoder interface and a 24 bit up/down counter. The level of the encoder signals can be TTL or RS422. Optionally, the encoder signals can be isolated on the transition module by high speed optocouplers. The encoder signals pass a digital filter for noise suppression before they are fed into the counter and the reference logic. The counter is programmable for single, double and quadruples analysis of the two encoder phase signals.



Calibration of the position feedback to an absolute reference point is done by programmable reference logic. Several modes of operation and hardware configurations for the reference switch and the encoder zero pulse are selectable. During normal operation the automatic recalibration of the measurement system is practicable with the "Auto-Reference" mode, whenever the system passes the reference location.

Two isolated 24V DC digital inputs have limit switch functionality. Each of these inputs drives a floating optocoupler output as hardware feedback. These outputs can be used to disable the power on the motor power amplifier, dependent on the actual direction. One additional isolated 24V digital input is for free use by the software, for example as emergency stop input. A floating optical output can be controlled by software, for example as enable signal for the motor power amplifier.

A 16 bit digital to analog converter (DAC) produces a +/-10V controller output signal which can be used as speed or torque source for the power amplifier of the motor drive system. A galvanically isolation of this signal with the help of an isolation amplifier will be supplied as a transition module option.

A 12 bit analog to digital converter (ADC) with a configurable input voltage range is also available.

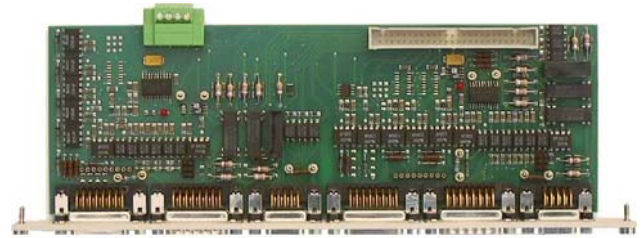

For First-Time-Buyers the Engineering Documentation TIP102-ED is recommended. The Engineering Documentation includes TIP102-DOC, schematics and data sheets of TIP102 and TIP102-TM.

Driver support (TIP102-SW-xx) is available for different operating systems.

Technical Information

TIP102

- Interface according to IndustryPack specification
- Identification-PROM supports auto-configuration
- Single Size IndustryPack
- 24 bit counter per axis (+/- 8.300.000 increments)
 - Programmable single, double or quadruples analysis of count signals
 - Maximum count frequency: 2 MHz
 - Digital signal filter for suppression of fast noise pulses
 - Any origin within driving range selectable
 - Auto-reference procedure
- 16 bit D/A converter per axis with +/- 10 V output signal to control servo amplifier
- 12 bit A/D converter per axis with adjustable input voltage range e.g. for connection of a joystick
- 4 inputs per axis for reference switch, limit switches, emergency stop
- 3 outputs per axis for control of axis enable and current limiting

TIP102-TM

- 50 pin flat cable connection to TIP102
- Signal distribution by three DB connectors per axis in a 6U / 1slot front panel
- Encoder interface directly to RS422 or TTL level
- Signal conditioning for all signals possible:
 - Isolation of all digital 24V I/O signals
 - Isolation of encoder signals
 - Isolation of analog output
 - Isolation of analog input

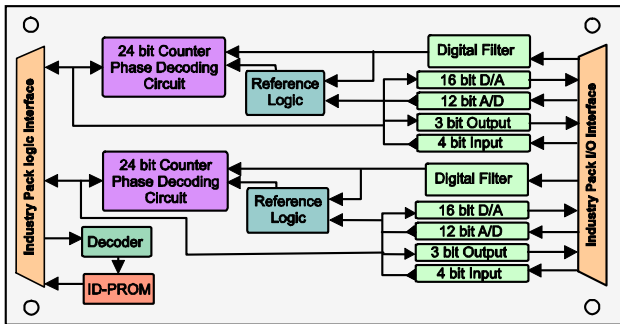

Block diagram TIP 102

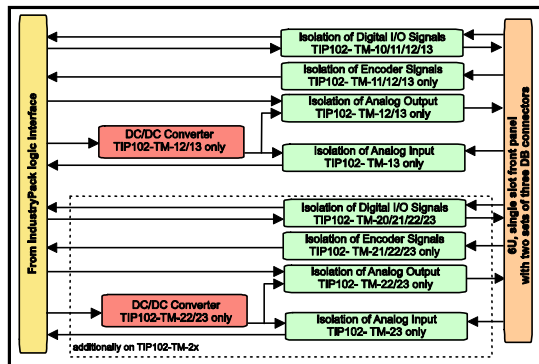

Block diagram TIP102-TM-xx

Order Information

- TIP102-10** One Axis Incremental Motion Controller
 - TIP102-10R** RoHS compliant version of TIP102-10

 - TIP102-11** As TIP102-10 but includes run-time-license for TIP102-SW-x2
 - TIP102-11R** RoHS compliant version of TIP102-11

 - TIP102-20** Two Axes Incremental Motion Controller
 - TIP102-20R** RoHS compliant version of TIP102-20

 - TIP102-21** As TIP102-20 but includes run-time-license for TIP102-SW-x2
 - TIP102-21R** RoHS compliant version of TIP102-21

 - TIP102-TM-10** Transition Module for TIP102-1x, provides isolation of all 24V digital I/O signals
 - TIP102-TM-11** As TIP102-TM-10 but add. isolation of encoder
 - TIP102-TM-12** As TIP102-TM-10 but add. isolation of encoder and analog output
 - TIP102-TM-13** As TIP102-TM-10 but add. isolation of encoder and analog input and output
 - TIP102-TM-20** Transition Module for TIP102-2x, provides isolation of all 24V digital I/O signals
 - TIP102-TM-21** As TIP102-TM-20 but add. isolation of encoder
 - TIP102-TM-22** As TIP102-TM-20 but add. isolation of encoder and analog output
 - TIP102-TM-23** As TIP102-TM-20 but add. isolation of encoder and analog input and output

 - TIP102-DOC** User Manual (TIP102 and TIP102-TM)
 - TIP102-ED** Engineering Documentation, includes TIP102-DOC

 - TIP102-SW-42** VxWorks Software Support
 - TIP102-SW-65** Windows XP/XPE/2000 Software Support
 - TIP102-SW-72** LynxOS Software Support
 - TIP102-SW-82** LiNux Software Support
 - TIP102-SW-95** QNX 6 Software Support
- For other operating systems please contact TEWS.